



The AI20 ink jet printer

Value without compromise



With clever design the entry level AI20 reduces your costs while meeting many of your general purpose coding needs.

Domino. Do more.

Simplicity and value

From the moment you press the start button the **AI20** delivers great value.

The clever design has reduced consumables usage while maintaining all of the strengths and value that the market has come to expect from the world's best selling Continuous Ink Jet (CIJ) printer.

Our entry level **AI20** is capable of meeting the need for a wide range of common applications where up to 3 lines of code is required.



A diverse range of applications

Domino's **AI20** is ideal for many coding applications where up to 3 lines of code is needed



Auto codes for best before dates



Traceability codes



Clear and easy to read codes



3 lines of code

30 years of Domino ink jet reliability doesn't happen by chance

295BK ink from Domino

- Quality design
- Quality process
- Quality materials
- Quality people

Domino's 295BK is at the heart of the printer ...



Greener credentials

Domino's commitment and investment in sound environmental practices means we frequently exceed the demanding governmental, industry and company standards and regulations. We are committed to minimising the consumption of natural resources and energy and the creation of waste. Additionally, our products are RoHS and WEEE compliant so that they are recyclable.

AI20

The AI20's efficient ink system reduces VOC emissions and advanced ink reduces waste. Weight has been reduced by 30% compared to the previous generation.

Simple to use – for stress free lines



Simple

The simple to use Field Based Editor allows you to create complex messages while reducing the need for operator training.

Secure

Eliminate coding errors with our in-built security manager:

Flexible

A wide range of print formats and speed/quality settings are all available from the simple User Interface.

Simplicity and value – all this from an entry level printer

Simplicity and value

If you are looking for a cost-effective solution for 3-line coding, then the AI20 is the printer you need: all in a rugged stainless steel IP55 cabinet.

Your costs are kept under control through our advanced ink system with our inks delivering low MU usage and extended reservoir life.

Easy to live with – because your time is precious



Consistent

You can leave the AI20 to get on with the job, through start up after start up and shut down after shut down, knowing that it will do more to perform with consistent quality.

Convenient

Just press a single button and walk away. We call it **SureStart**. It's our unique print head with a nozzle sealing and flushing process that guarantees consistent performance.

Reliable

Combined with good filtration, an independently heated head and measured viscosity control, Domino's AI20 does more to ensure it keeps working.



Domino. Do more.

Technical Specification:

A120

Operational Capability

Max number of messages	300
Max number of characters per field	256
Max number of fields per message	40
Logo generation	On board
Max number of logos	250
Max number of strokes per logo	2000
Max print format height	25 drops
Max number of lines of text	3
Max line speed	148m/min

Interfaces

QVGA (320x240) with key board	Standard
4 Stage 24V beacon	Optional
4 Stage alarm (voltage free contacts)	Optional
Product detector	Standard
Shaft encoder	Standard

Environment

Weight	23kgs
Stainless Steel	304 or equivalent
IP Rating (designed to)	55
Operating temperature (ink dependent)	5 °C to 45°C
Humidity	10% to 90%
Power requirement	96-256v 47-63hz
Power consumption	56Watts

Compliance

CE	Standard
RoHS	Standard
Sony Green Partner	Standard
Eupia compliant inks	Standard

Print head

Conduit length	3m
Bend Radius	45mm
Nozzle size	60µ

SureStart

Heater	Standard
Positive air pump	Optional

Ink System

Ink Cartridge	825ml
MU cartridge	825ml
Ink Reservoir	1200ml
Solvent Reduction (Peltier)	Optional

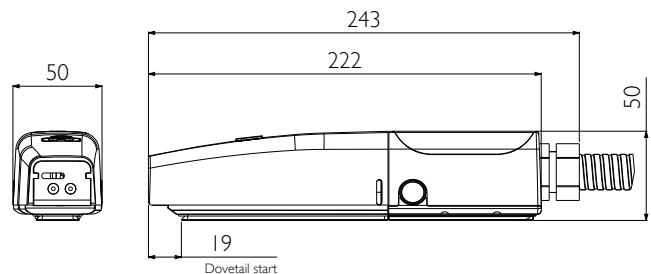
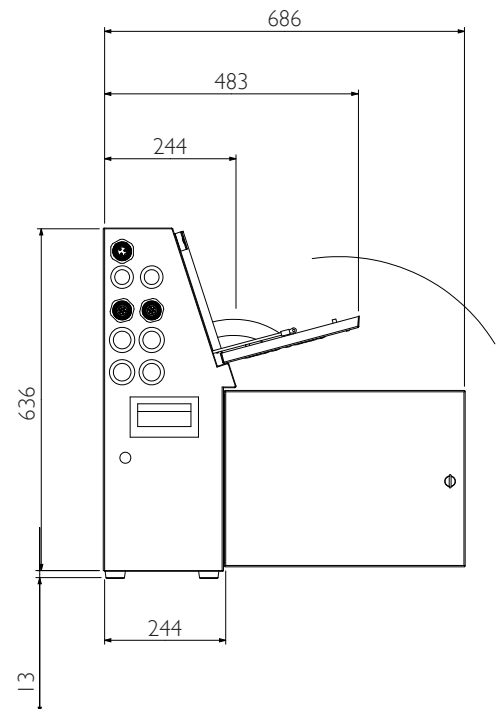
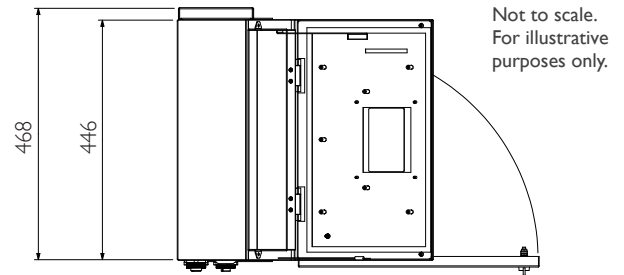

Print Sample



Representative print quality only – achievable print quality dependent on substrate and printer operation conditions.